

Potting machine TM 2432

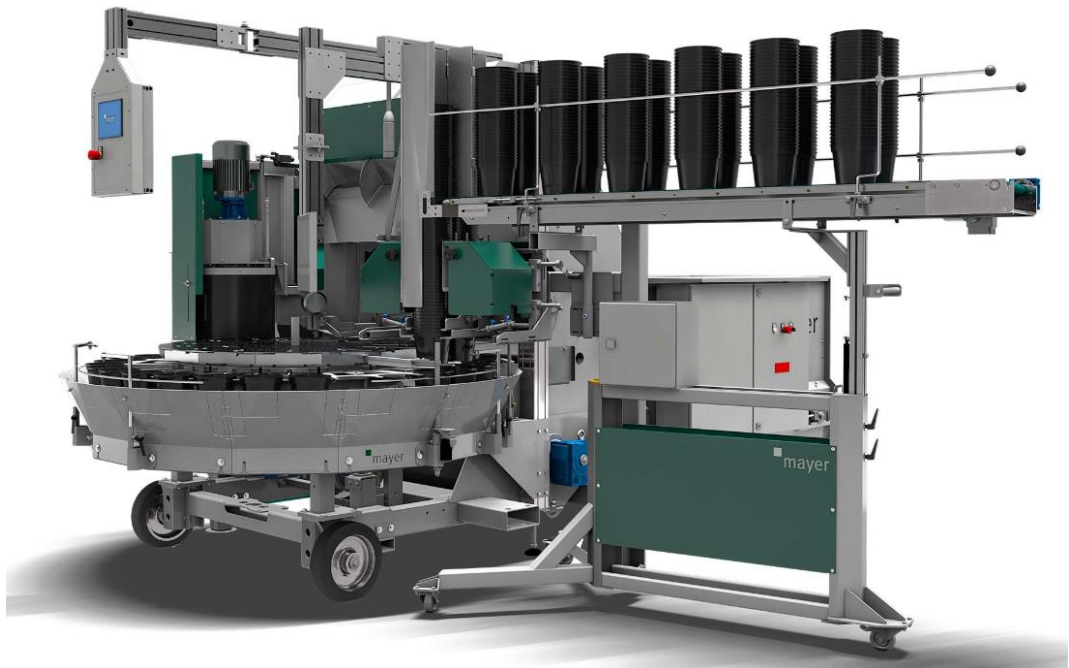

Operating instructions

Issue date: 01/09/2021 / V1.5

Before the initial start-up, read and keep at the machine for future use.



List of Contents

1 Product description

- 1 Intended use
- 2 Structure
- 3 Functional description
- 4 Technical data
- 5 EC Declaration of conformity

2 General safety instructions

- 1 Due diligence of the operating company
- 2 Explanation of the safety symbols used
- 3 Basic safety precautions
- 4 Machine-related safety precautions
- 5 Demands on operating personnel

3 Transport, handling and storage of the machine

- 1 Transport
- 2 Handling
- 3 Storage

4 Installation

- 1 General notes
- 2 Installing the machine
- 3 Measures for the machine's stability against overturning
- 4 Disassembly and disposal of the machine

5 Initial start-up

- 1 Check prior to first start
- 2 a Starting the machine with Touchscreen for the first time
- 2 b Starting the machine without Touchscreen for the first time
- 3 Stopping the machine

6 Operation

- 1 Normal operation
- 2 Shutting down the machine
- 3 Measures prior to and after a longer shutdown

7 Malfunctions

- 1 Behaviour in case of malfunctions
- 2 Possible malfunctions and trouble shooting

8 Maintenance

- 1 General notes
- 2 Inspection and preventive maintenance
 - 2.1 Elevator chains
 - 2.2 Rubber conveyor belt
- 3 Maintenance schedule

9 Part list

10 Circuit diagrams for electric and pneumatic system

11 Guarantee

1 Product description

1 Intended use

The Mayer TM 2432 potting machine may be used for planting and replanting plants with a minimum of working force and of time.

Other means of use of the machine, besides the ones listed here, are not permitted – and they are not the usage for intended purpose.

If the Mayer TM 2432 potting machine is not used in accordance with the regulations, the safe operation of the machine is not guaranteed.

The usage for intended purpose involves reading the operating instructions, and compliance of the regulations, specially safety regulations stated in them. Furthermore, every inspection and maintenance should be performed in specified time.

The manufacturer accepts no liability for damages resulting from improper use. The operator of the Mayer TM 2432 is solely responsible for personal injuries or property damages.

2 Structure
Plan view 2432

back

left

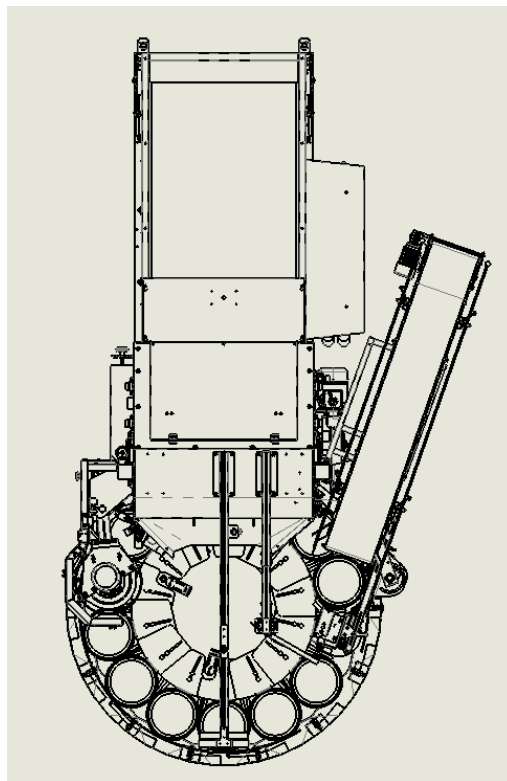

right

front

3 Functional description

a) Working without automatic pot dispenser

When there is no pot dispenser installed, then empty pots are loaded by one person on the turntable located on the right side of the machine when it is viewed from front side.

The turntable is driven by a worm drive mechanism and is moved intermittently in counter-clockwise.

The pots are forwarded under the elevator.

Plates are fixed on endless chains located in the elevator housing which take the soil from the hopper. When the plates reach the upper turning point, the soil falls into the pot being there.

A controlled conveyor belt is installed into the soil hopper which forwards the soil always towards the elevator.

The turntable continues to turn and a drilling motor, synchronously with the turning mechanism, drills a hole into the soil in the pot by means of a replaceable drill.

One or several person(s) standing around the machine plant plants into the pots. Plant holding trays can be located either beside the machine or in a separate storing place or on top of the turntable.

A pot take-off is installed to remove the planted pots from the turntable and to push them on a conveyor belt connected to the machine.

Warning!

When there is no automatic pot dispenser installed, special care shall be taken on section 2 „General safety instructions”.

b) Working with automatic pot dispenser

When there is an automatic pot dispenser installed then feeding by hand is not necessary and one labour force may be saved.

Further instructions are detailed in Operation instructions of pot dispenser.

4 Technical data

Make:	Mayer
Machine type:	Potting machine
Series:	2432
Length / width / height:	460 / 220 / 230 cm
Weight:	ca. 1700 kg
Working height:	ca. 100 cm
Power connection:	400V/50Hz, 5-pole
Power input:	3 kW
Pot size:	T14 pots, 9-32 cm diameter (for round and square pots)
Capacity of soil hopper:	1,5 m ³ 2,2/3,0 m ³ on request
Production speed:	up to 3,000 pots/hour
Usable drill sizes:	2 -13 cm larger drill diameter on request
Workplace related emission value:	73dB (A)

Available accessories (for an additional charge)

- Pot holder ring for pots from 9 to 13 cm diameter
- Drill sleeve 100 mm
- Standard drills from 3.5 – 13 cm
- Special drills from 3.5 – 16 cm
- Container drill from 11 – 16 cm
- Plate from 4.0 – 14 cm
- Plates for tree nurseries from 12 – 18 cm
- Closed pressure plate
- Special pressure plate
- Chrysanthemum plate
- Plates for pouring edge
- Roller conveyor and roller curves
- Counting device
- Various pot dispensers
- Automatic pot transport in combination with conveyor belts
- Broadening devices and attachments for soil hoppers
- Trailer coupling
- Stainless steel elevator buckets
- Rotating motor brush
- Fertilizer dispenser
- Special tyres
- Additional frequency converter
- Soil control on the elevator
- Platform segments

Important note!

When placing repeat orders for accessories and spare parts, make sure to have information about the machine type and number at your hand!

5 EC declaration of conformity

According to Appendix IIA of the EU Machinery Directive (2006/42/EC)

The manufacturer

Mayer Ipari és Kereskedelmi BT.
Georg Mayer út 1. 9341 Kisfalud / Hungary

Mayer GmbH & Co. KG
Maschinenbau u. Verwaltung
Poststr. 30 89522 Heidenheim / Germany

hereby attests that the machine described in the following:

Make: Mayer
Model: Topfmaschine
Series: 2432
Year constructed: since 2020

fulfils the safety and health requirements of the following EU Machinery Directive:

2006/42/EC

Applied harmonised standards:

EN ISO 12100:2011	Safety of machinery. General principles for design. Risk assessment and risk reduction (ISO 12100:2010)
EN 60204-1:2010	Safety of machinery. Electrical equipment of machines. Part 1: General requirements (IEC 60204-1:2005, modified)
EN ISO 13849-1:2016	Safety of machinery. Safety-related parts of control systems. Part 1: General principles for design (ISO 13849-1:2015)
EN ISO 13850:2008	Safety of machinery. Emergency stop. Principles for design (ISO 13850:2006)
EN ISO 13855:2010	Safety of machinery - Positioning of safeguards with respect to the approach speeds of parts of the human body (ISO 13855:2010)
EN ISO 13857:2008	Safety of machinery. Safety distances to prevent hazard zones being reached by upper and lower limbs (ISO 13857:2008)
EN ISO 14119:2014	Safety of machinery. Interlocking devices associated with guards. Principles for design and selection (ISO 14119:2013)
EN ISO 4413:2011	Hydraulic fluid power - General rules and safety requirements for systems and their components (ISO 4413:2010)
EN ISO 4414:2011	Pneumatic fluid power - General rules and safety requirements for systems and their components (ISO 4414:2010)
EN 349:1993+A1:2008	Safety of machinery. Minimum gaps to avoid crushing of parts of human body.
EN ISO 14120:2016	Safety of machinery. Guards. General requirements for the design and construction of fixed and movable guards. (ISO 14120:2015)
EN 1037:1995+A1:2008	Safety of machinery. Prevention of unexpected start-up
EN 618:2002+A1:2011	Continuous handling equipment and systems - Safety and EMC requirements for equipment for mechanical handling of bulk materials except fixed belt conveyors
EN 619:2002+A1:2011	Continuous handling equipment and systems - Safety and EMC requirements for equipment for mechanical handling of unit loads
EN ISO 14738:2009	Safety of machinery. Anthropometric requirements for the design of workstations at machinery. (ISO 14738:2002, + Cor 1:2003 + Cor 2:2005)

EN 1005-2:2003+A1:2009	Safety of machinery. Human physical performance. Part 2: Manual handling of machinery and component parts of machinery
EN 1005-5:2007	Safety of machinery. Human physical performance. Part 5: Risk assessment for repetitive handling at high frequency.

Any design alterations that effect the technical specifications given in the Operating Instructions or the intended use, i.e. change the machine substantially, will invalidate this EU Declaration of Conformity.

Heidenheim, 01/09/2021

.....
Geschäftsführer | Managing Director



2 General safety instructions

1 Due diligence of the operating company

The Mayer TM 2432 potting machine was designed and built taking a danger analysis into consideration and after careful selection of the harmonised standards to be complied with as well as other specifications. It therefore meets the state of the art and guarantees a maximum degree of safety.

However, only if all the measures required for such are taken can this safety be achieved in actual operational practice. Planning these measures and checking their implementation is subject to the operating organisation's duty to take due care.

The operating organisation must in particular guarantee that:

- ... the machine is only used in accordance with its intended use (cf. Product description).
- ... the machine is only operated when in flawless working order and, especially, that the working order of the safety equipment is regularly checked.
- ... the Operating Instructions are always available in legible condition and complete at the location where the machine is used.
- ... only sufficiently qualified and authorised personnel operate, service and repair the machine.
- ... these personnel are regularly instructed about all relevant matters concerning industrial safety and environmental protection and that they know the Operating Instructions and especially the safety instructions they contain.



- ... none of the safety and warning signs attached to the machine are removed and that all remain legible.
- Users must obligate themselves only to ever operate the machine when it is in flawless condition.
- No unauthorised conversions or alterations are allowed that influence safety of the machine.
- Only when it has stopped, must any work ever be carried out on the machine.
- Before beginning with any work on the machine, secure its drives and accessory parts against being switched on unintentionally.
- The protective devices may only be removed when the machine has been stopped.
- Local safety and accident-prevention regulations always apply to any operation of the machine.

- The machine may not be started if any safety devices are removed.
- In the working area the operator is responsible for other people.
- **In case of non-compliance with any one of the points cited above, the manufacturer shall be released from all liability.**

2 Explanation of the safety symbols used

The safety symbols along with the text of the safety instructions are meant to point out unavoidable residual dangers that exist when dealing with this machine. These residual hazards relate to:

- People
- The machine
- Other things and objects
- The environment

The following safety symbols are used in these Operating Instructions:

This symbol indicates that there are dangers to the machine, things and the environment, but that no dangers to people are to be expected. If these instructions are not followed, it might result in malfunctions and damage to the machine. Property damage and environmental damage might also come about



This symbol identifies instructions contributing to better understanding of the machine, information that helps you to use the machine in optimum fashion. This symbol does not identify safety instructions.

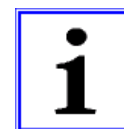

This symbol warns against the danger of electric shock.



Be sure to also note that a safety symbol can never replace the text of safety instructions – the text of safety instructions must therefore always be read completely!

3 Basic safety precautions

Always be sure that:

- ... tight-fitting working clothes are worn at all the workplaces.
- ... it is not allowed to wear chains, rings, bracelets or wristbands.
- ... for operationally relevant reasons, it is not possible to completely cover the compost hopper.
- ... it is not allowed to reach into the compost hopper (to push in more soil, for example), because when doing so, there would be a danger of getting caught by the scraping chain.
- ... it is not allowed to get into the compost hopper while the machine is running.
- ... it is not allowed to reach into the turntable or pot dispenser while the machine is running.
- ... it is not allowed to reach into the drilling stand while the machine is running.
- ... it is not allowed to reach into the pot transfer while the machine is running.

4 Machine-related safety precautions

The workplaces are spread over various areas of the potting machine.

a) Feeding pots into the rotating assembly (for a machine without pot dispenser) or feeding pots into the pot dispenser (for machines with pot dispenser) on the right side of the console.

b) Filling the soil hopper with substrate from the rear or from the right or left side.

c) Potting plants on the front left of the console, between drilling stand and pot transfer. Alternatively, they can also be potted on the conveyor belts.

Responsibilities for the various activities must be clearly defined and complied with. Unclear competencies represent a safety risk.

Persons who are engaged in putting single pots into the rotating assembly must have been given separate training, during which it was pointed out to them that there is a potential danger of being drawn into the machine if they got stuck at the rotating assembly.

For procedural reasons it is not possible for the soil hopper to be covered completely. However, the available cover provides a certain protection against the circulating elevator chains.

It is forbidden to reach into the soil hopper (for example to refill the soil), because when doing so there would be a danger of getting caught by the elevator chains or buckets.

It is not allowed to get into the soil hopper while the machine is running.

For procedural reasons it is not possible for the rotating assembly to be covered.

When potting at the rotating assembly, there is a potential hazard of getting stuck in there due to carelessness or wearing further additional clothing or jewellery.

In case of malfunctions during the work flow it is forbidden to touch the running machine in order to resolve the malfunction.

It must always be possible to access the emergency cut-off switch.

The flexible emergency cut-off switch should always be located on the relevant workplace (during normal operation preferably on the console, next to the right of the worker).

It is forbidden to climb onto the running machine.

The machine must be set up on even and solid surface so that it stands securely in place. There is danger of life in case the machine is falling over.

The floor (workplaces at the machine and traffic routes) must be regularly cleaned from dirt and water in order to avoid danger of slipping.

Stumbling blocks in the form of cables connected to the energy supply systems must be avoided.

All feed lines to the machine must be protected against damage.

Only a skilled electrician is allowed to carry out works on the electrical equipment.

Protection devices

- are fitted for the safety of operating personnel
- may in no case be changed, removed or evaded by modifications to the machine.

Frequency converters can cause fault currents that are not detected by means of a standard soil leakage circuit breaker. Therefore, the machine may be operated with an AC/DC sensitive RCCB (residual-current circuit-breaker) only.



Frequency converters have built-in capacitors that discharge after switching off the machine. The machine's connecting plug may be pulled out of the outlet not before approx. 1 to 2 minutes after switching off the main circuit breaker.

5 Demands on operating personnel

The machine may only be operated by personnel who have been trained for such, shown what is involved and are authorised to do so. These individuals have to know and act in accordance with the Operating Instructions. The respective authorisations for the operation personnel must be clearly prescribed.

In addition, special qualifications are required for the following activities:

Operation personnel being trained may at first only work with the machine under the supervision of an experienced individual. It should be confirmed in

writing that the training has been successfully completed.

Only trained personnel may ever operate any of the control and safety equipment.

All individuals that carry out any activities with the machine have to read the Operating Instructions and confirm by their signature that they have understood the Operating Instructions.

3 Transport

To prevent damage to the machine as well as injuries while transporting the machine, it is absolutely necessary to comply with the following points:

- Transport work may only be carried out by individuals qualified to do so, complying with the safety instructions.
- The machine may only be lifted by the supporting points provided for such.
- Only the load-lifting devices and tackle specified here may be used to transport the machine.
- Be sure to also read section "General Safety Instructions".

When transporting the machine, the following special dangers must be expected:

- Suspended loads can drop, which would be a lethal danger – never go under suspended loads!
- If load-lifting equipment other than that specified here, severe damage to the machine may result.

1 Transport

When the machine is transported, special care shall be taken to avoid damage of the machine during loading or unloading.

During transport fixings shall be implemented according to type of transport.

Moisture condensation caused by temperature difference during transport as well as shocks during transport shall be avoided.

The machine shall be operated with usual care.

It is recommended to use a relevant attachment when loading or unloading the machine by means of a forklift.



2 Handling

The potting machine is fitted with 2 rubber tyres on one axle on the front and 2 castors on the soil hopper. The weight of the empty machine is balanced on the axle. On request, a trailer coupling can also be attached for an additional charge.

When the machine is moved, pay particular attention to the supply lines to the machine to prevent that the lines are damaged and/or ripped out of their couplings if the machine runs over them with the front wheels.

If the machine is to be moved over an inclined plane, it is necessary:

- to completely empty the soil hopper,
- to make sufficient safety precautions in order to prevent the machine from accidentally rolling away.

Such precautions may include:

- enough personnel
- to secure the wheels using a wedge
- and so on

3 Storage

When the machine or its parts are not reassembled right after transport, then they shall be carefully stored in a protected area. It shall regularly be covered and protected against dust and moisture.

Tasks for putting out of operation are detailed in section 6.3.



4 Installation

1 General notes

a)

To protect the machine against weather caused damages it is suggested to use and store it inside.

b)

Electrical connection: 400V/50Hz.

Connection is permitted only to socket-outlets which are protected by an AC/DC sensitive RCCB (residual-current circuit-breaker).

c)

Be sure that enough place is assured for feeding and filling pots. Same care shall be taken in case of machines connected in front of or behind it.

d)

In order to utilize the capacity of the machine, it is suggested to prepare soil mixture, seedling, plants, pots, trays on the best place and in sufficient quantity.

Do not underestimate the job to remove and transport the filled pots, since an insufficient solution may considerably decrease efficiency of the machine.

2 Installing the machine

- a) A hard and even soil surface shall be provided under the machine to prevent the wheels and castors from sinking into the soil.
- b) In order to ease the pneumatic tyres, prop up the machine using the support legs.



3 Measures for the machine's stability against overturning

There is no need to carry out other activity for erecting the machine than it is described in section 4.2.

4 Disassembly and disposal of the machine

After completion of its full time of operation, the machine must be duly separated from energy supply systems and disposed of according to valid legal regulations.

5 Initial start-up

It is essential to comply with the following safety instructions for the initial start-up of the machine. This will prevent injury to individuals, damage to machinery and other property damage.

- The initial start-up may only be carried out by qualified individuals, complying with the safety instructions.
- Before the first start-up, check whether all the tools and parts not belonging to it have been removed from the machine
- Before the first start-up, check the electrical connections.
- Activate all the safety equipment and EMERGENCY SHUT-OFF switches before the initial start-up.
- Also read the section "General Safety Instructions".

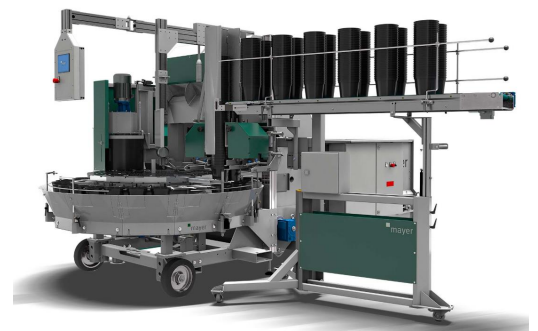

1 Check prior to first start

Prior to starting up the machine, the following must be checked:

- are all safety devices available?
- was the machine damaged during transport?
- all visible bolted joints must be checked for tight seat.
- prior to putting the machine into operation, the connecting cable of the machine and the cable of the emergency cut-off switch must be checked for damages.

2 a Starting the machine with Touchscreen for the first time

The machine shall be checked as per the following:

a)

Be sure that no foreign materials, such as tools or similar, are left in the soil hopper, in the elevator or on the turntable.

b)

Put the main switch of the machine to OFF („Null“) position before the plug of the connection cable is connected to the socket.

c)

When the machine is connected to the electricity, put the switch to „1 ON“ position.

d)

Prior to starting, connect compressed air (6 to 8 bars).



Press the green button „Enable“ („Freigabe“) on the control panel above the turntable for 2 seconds at least, till it lights up.

After pushing the „Start“ button on the control panel or on the flexible „Start-Stop“ switch, the turntable will start to rotate counter-clockwise.

If it rotates clockwise, then call an electrician to change phases at the connecting cable.

Buckets of the elevator shall be forwarded from bottom towards top seeing from side of soil hopper.



e)

In case there were no problems found or unusual noises heard during test operation, the machine may be put into operation as it is described in section „Operation“.



2 b Starting the machine without Touchscreen for the first time

The machine shall be checked as per the following:

- a) Be sure that no foreign materials, such as tools or similar, are left in the soil hopper, in the elevator or on the turntable.
- b) Put the main switch of the machine to OFF („Null”) position before the plug of the connection cable is connected to the socket.
- c) When the machine is connected to the electricity, put the switch to „1 ON” position.
- d) Prior to starting, connect compressed air (6 to 8 bars).



Put switch of turntable to „1 ON” position, while switch of elevator and conveyor belt to right to position „1”, as well as switch of drill to position „2”. Press pushbutton „Start” on „Start-Stop” switch of swinging cable and the turntable starts to rotate counter clockwise.

If it would rotate clockwise then call for an electrician to change phases at the connecting cable.

Plates of the elevator shall be forwarded from bottom towards top seeing from side of soil hopper.

Care shall be taken on the following:

With the potentiometer, „Soil” means:

- turn to the right
> larger amount of soil and more speed
- turn to the left
> smaller amount of soil and less speed



Warning!

- Switch position to right: elevator and conveyor belt are moved in normal operational direction.
- Switch position to left: conveyor belt is moved in normal operational direction while elevator is moved in opposite direction.

Changeover switch „Drill” („Bohrer”):

- switch position „2”: drill is rotated clockwise
> it excavates the soil.
- switch position „1”: drill is rotated counter-clockwise > it compacts the soil.
(only possible with standard drill)

- e) In case there were no problems found or unusual noises heard during test operation, the machine may be put into operation as it is described in section „Operation”.

3 Stopping the machine

There are two ways to switch off the machine:

a)

In normal case by switch „Stop” on the control panel or on the flexible „Start-Stop” switch.

b)

In case of emergency by the „Emergency Stop” switches.

Note:

See also section "6.2 – Shutting down the machine"

6 Operation

1 Normal operation

a) Before starting operation the following shall be checked:

- Are pots, plants and soil mixture available in sufficient quantity?

Care about:

- Soil transport
- Plant feeding and unloading
- Pot preparation
- Use the shortest transport routes

b) Adjusting or shifting the pot turntable

- Hight adjustment turntable



- Adjust pot diameter



- Adjust substrate support to pot height by means of crank handle

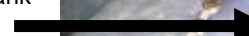

- Adjust soil supports to the diameter of the pots



- Adjust brush so that it sweeps excess soil from pots



- Adjust the brush by means of the hand wheel from the outside:
 - clockwise > higher
 - counter-clockwise > lower



- Adjust lower scraper brush in such a way that it cleans the pot support.
- Adjust upper scraper brush in such a way that it cleans the clamps of the pot holding discs.



c) Soil feeding and emptying the machine

The soil hopper contains 1,500 litres and can be fed in various ways without the workflow at the machine being disturbed or interrupted.

Feeding can take place:

- manually by means of a shovel
- using a wheelbarrow
- using a conveyor belt
- using a shovel loader
- using a big bale chopper
- and so on.

The remaining soil can be conveyed out of the machine by opening the soil flaps. If the soil heap gets too high in front of the soil flap opening, the potting machine must be pulled back a bit. Cleaning the elevator deflection also takes place by means of the soil flap openings.



d) Adjusting drill depth and pressure intensity of plates

After fixing the size of the soil drill and the matching plate, drilling depth must be set according to the bale's height of the product to be potted.

Proceed as follows:

- Open the drill support's door

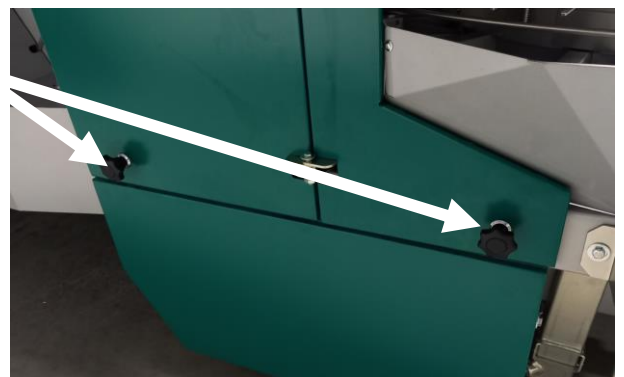

- Tight-screw the plate to the holding down bars using self-locking nuts.



- Set the drilling slide to lower position.



- Apply a suitable spindle on the drill and slide them on shaft of the motor then fix them by means of a threaded pin.



- Set the required drilling depth roughly by using an empty pot.

- Drilling depth may be adjusted by shifting the rod in the sleeve and fixing them to each other by means of the threaded pin.
- Then make a test drilling with a pot filled up with soil and check the drilling depth, readjust if necessary.
- When soft plastic, grided or Jiffy type pots are used, pressing force of the press plate shall be set by using clamping pieces.



**e) Adjusting the speed of operation with Touchscreen
(hourly output)**

On special model with Touchscreen

Infinitely variable adjustment can be carried out only if the machine is running by turning the potentiometer (optional) on a scale of 1 to 10 to run faster or slower.

For initial work with the potting machine, we recommend to start with a low hourly output until all workers have complete command of individual work steps.

c.f.

TM2432 Operating manual E7114-15-05 (attached)



On standard model without Touchscreen

Infinitely variable adjustment can be carried out only if the machine is running by turning the potentiometer on a scale of 1 to 10 to run faster or slower.

For initial work with the potting machine, we recommend to start with a low hourly output until all workers have complete command of individual work steps.



f) Adjusting the soil

Supply of soil from the soil hopper to the elevator takes place by means of a continuous rubber conveyor belt, running on carrier rollers in the soil hopper.

There are 2 options to control the soil amount to be fed:

I.

On special model with Touchscreen

By setting different potentiometer (optional) positions on the elevator and rubber conveyor belt:

- to the right (clockwise) > large amount of soil
- to the left (counter-clockwise) > small amount of soil

c.f. TM2432 Operating manual E7114-15-05 (attached)



On standard model without Touchscreen

Infinitely variable adjustment can be carried out only if the machine is running by turning the potentiometer on a scale of 1 to 10 to run faster or slower.

For initial work with the potting machine, we recommend to start with a low hourly output until all workers have complete command of individual work steps.



II.

Speed of the belt may be increased or decreased by rotating the star wheel as it is marked.

Before setting is started, clamping lever of spindle of the star wheel shall be loosened and when the required speed is set, it shall be tightened.

When the quantity of soil is set, always make setting by only one or two rotations and then wait until 40-50 pots are filled. Then correction may be made if it is necessary.

Note:

Please, make sure that only a required amount of soil is set. This will release the elevator and ensure longer service life.



g) Setting compactness of the soil (in the pot)

A special feature of Mayer potting machines is that you can set the compactness of the soil in the pot.

This depends on:

1. Drilling in or out the soil mixture
2. Setting the filling quantity by setting the drawer
3. Type and size of pressing plate

Comment to 1:

Depending on the relevant setting of the drill motor's reverse switch, you can operate an anti-clockwise or clockwise rotation of the drill (counter-clockwise rotation is possible only with standard drill).

When it rotates clockwise, it drills out the soil, and when it rotates counter-clockwise, it drills in the soil (compacts). Cross shaped plate of standard drill bit distributes the soil in the pot.

The standard drill may be used in both directions.

Special drills may only be used for drilling out. Flat edge of the drill bit and deep grooves are especially favourable in case of thick soil mixtures, pine-needles and for loose filling.

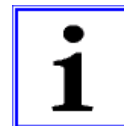

Comment to 2:

Filled in quantity may be set by the drawer with adjustable height. Larger quantity of soil results in more compact filling while soil filling drawn down at the edge of the pot results in loose filling.

Comment to 3:

Function of the pressing plate is to hold the pot and to keep rest of the soil during drilling. When the gap between outside diameter of the drill and hole of pressing plate (e.g. 6 cm dia. drill with pressing plate hole dia. of 7 cm) is small, then only a little amount of soil is removed and the filled soil is compact. When this gap is larger (e.g. 6 cm dia. drill with pressing plate hole dia. of 9 cm), larger amount of soil is removed and the filled soil is less compact. The pressing plate with soil addition leaves a soil heap on the pot which may be compacted by

repressing. Special accessories shall be used for special tasks and for special pots.

Various designs of plates:

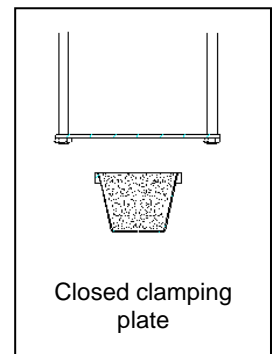
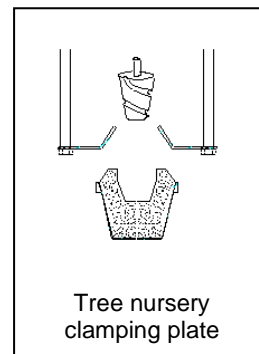
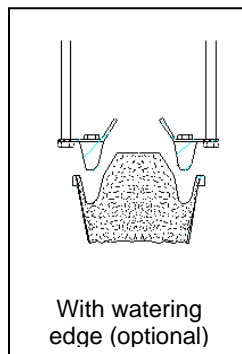
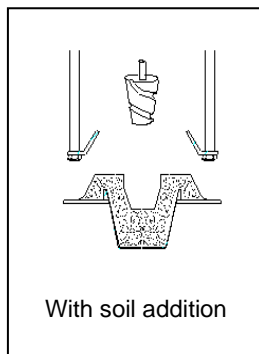

h) Soil chute

- Adjustment of inclination



i) Adjustment of 3 soil chutes for additional soil supply on the soil support

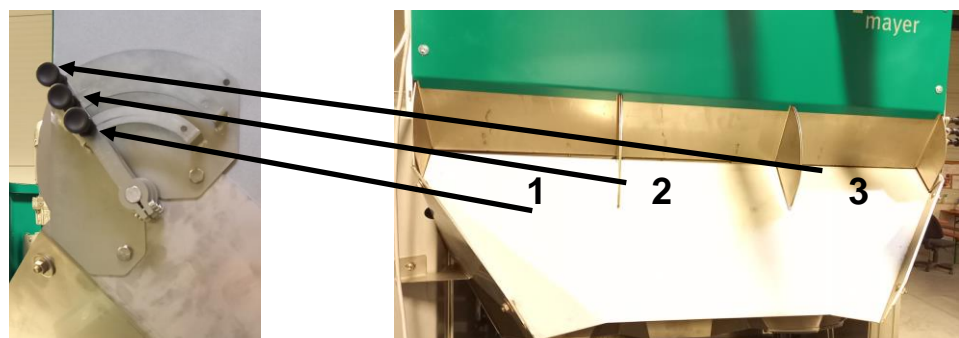

j) Motor brush (optional)

- Adjustment from the outside

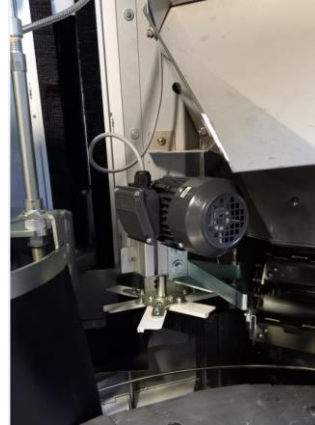

2 Shutting down the machine

There are two ways to switch off the machine:

a)

In normal case by pressing switch „**Stop**” mounted on the swinging cable.

In this case the machine may be restarted by pressing switch „Start”.

b)

In emergency case by „**Emergency Stop**” switch.

When push button „Emergency Stop” is pressed, the machine stops immediately and remains stopped. After „Emergency Stop” is eliminated, the machine may be started by pressing push button „Start”.

3 Measures prior to and after a longer shutdown

a) Before a long shutdown

- Clean the machine carefully.
- Grease and oil certain parts of the machine according to maintenance plan.
- Protect against dirt and moisture (to be covered)
- Disconnect the machine from power lines (electricity, compressed air)

b) After a long shutdown

- Grease and oil certain parts of the machine according to maintenance plan.
- Visually check the machine.
- Connect the machine to required energy sources.
- Start the machine as it is described in section „Initial start-up”.

7 Malfunctions

To prevent damage to the machine as well as injuries while eliminating malfunctions at the machine, it is necessary to comply with the following points:

- Eliminate a malfunction only if you have the qualification specified to do so.
- Also read section "General Safety Instructions".
- When eliminating malfunctions at the machine, the following special dangers have to be expected:
 - Accidentally switching on the power sources can result in injuries to people as well as damage to the machine.
 - In case of unprotected manual operation, there is an increased risk of injuries through bruising.

1 Behaviour in case of malfunctions

If any malfunctions occur while the machine is in operation, proceed as follows:

1. Stop the machine either using the STOP button or EMERGENCY SHUT-OFF, depending on the situation.
2. When necessary for the safety of people or of the machine, immediately cut off the machine from the power system it has.
2. Troubleshooting > If necessary, then by qualified personnel
3. Error correction > If necessary, then by qualified personnel
4. Start up the machine.

2 Possible malfunctions and trouble shooting

a) Mechanical malfunctions

Failure/Malfunction	Cause	Trouble shooting
Noise in the elevator	Foreign matter got stuck	Remove cause for malfunction. Possibly by running elevator backwards for a short time.
Rotating assembly has too much clearance.	Worn shifting roll or carrier bolt	Replace shifting roll or carrier bolt.
	Chains are too loose	Retighten chains.
Erratic filling of pots	Matter in elevator	Remove source of interference.
	Soiled buckets	Clean buckets.
No soil supply	Soil hopper empty	Fill hopper.
	Broken return spring at free wheel hub	Replace spring.
Pot supply interrupted	Wrong settings	Check settings.

b) Electrical malfunctions

Failure/Malfunction	Cause	Trouble shooting
Motor protection switches off	Fault in electronics	Electronic parts shall be checked by a skilled electrician
	Mechanic overload	Remove the foreign material causing overload

8 Maintenance

When carrying out maintenance for the machine, it is necessary to comply with the following safety instructions. Doing so will prevent injuries to people, damage to the machine and other damage to property as well as the environment.

- **Cleaning, lubricating and maintenance work may only be carried out by authorised operating personnel. The Operating Instructions must be complied with exactly.**
- Only trained electricians may ever carry out any of the work on the machine's electrical equipment.
- Switch off all sources of voltage and secure the sources of voltage against being accidentally switched back on.
- Release pressure of every unit that is under pressure.
- Only Mayer GmbH & Co. KG may ever manipulate the machine's control programme.
- All un-recycled operational materials, lubricants and supplies must be disposed of in an environmentally friendly manner.
- Also read section "General Safety Instructions".

When carrying out maintenance on the machine, the following special dangers have to be expected.

- Installing incorrect spare parts or wearing parts can cause severe damage to the machine.
- Accidentally switching on the power source can result in severe bodily injuries and damage to the machine.
- There is a danger of getting injured on sharp-edged machine parts/tools that are exposed.
- Lubricants or fertilisers that have escaped can result in caustic burns on direct contact with the skin.
- When unsecured manual operation is carried out, there is an increased risk of injury through crushing.

1 General notes

We recommend an annual inspection of the entire machine by our customer service.

For service or repair work, order our customer service at one of our service workshops.



Spare parts have to meet the technical requirements of the machine's manufacturer. This is guaranteed with original spare parts from Mayer.

2 Inspection and preventative maintenance

2.1 Elevator chains

Chains may be retensioned by means of tensioning bearings located on two sides of the elevator. Check regularly if the chains are tensioned properly. When the chain is too loose, the plates may jam with edge of the housing.

Overtensioned chain requires an excess of driving power and causes too quick wear. When the chains are retensioned, both of them shall have the same tightness. With the soil hopper being completely empty and the elevator being at the height of the pot holder, normal tension is available when the chain can be moved about 3-4 cm by hand.



Grease elevator chain prior to a longer shutdown!

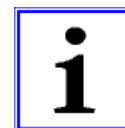

2.2 Rubber conveyor belt

Generally the rubber belt requires no retensioning.



However, if the belt should be readjusted caused for example by repair works carried out on the machine, follow the process described as below:

Tensioning of the belt may be adjusted by means of tensioning nuts located at the end of soil hopper. It is important that both sides of the belt are tensioned equally.





Beyond the above, make sure that grooves of driving and guiding drum are not filled up with soil. Regularly clean the grooves when it occurs.







Follow the maintenance schedule.



3 Maintenance schedule

Description	Interval	
Check function of safety devices	daily	
Using compressed air, clean guide rods of drilling unit	daily	
Clean shovels (cleanout cf. photo)	daily	
Check intactness of safety instructions	weekly	
Check tension of elevator chain	weekly	
Check drive chain of drilling stand and if necessary, retighten it	monthly	
Grease shifting roll's groove and drive chains	quarterly	
Grease 4 times rotating assembly brakes	half-yearly	

Grease holding-down bar at drill	yearly	
Grease all bearings fitted with grease nipples	yearly	
Grease all bearings on the turntable fitted with grease nipples	quarterly	
Retighten rubber conveyor belt (soil hopper)	after repair works	

9 Part list

10 Circuit diagrams for electric and pneumatic system

11 Guarantee

Horticultural machinery and special machinery

We will accept liability for faults in the supplied goods and for any failure to provide features for the existence of which an express assurance had been given. In such a case we undertake – to the exclusion of all further claims – to improve or re-supply (at our discretion) free of charge any parts which have revealed themselves to be unserviceable or subject to a not inconsiderable impairment in serviceability due to faults in their material, manufacturing process or design within twelve months (or within six months for multi-shift operation) of their arrival on the customer's premises. For parts which we do not manufacture ourselves (e.g. motors), we can only accept liability for the same scope and length of time which the subcontractor has accorded to us.

Any replaced parts shall become our own property. No warranty claims can be accepted if the fault occurs as a result of the customer having mistreated or neglected the products delivered by us, made modifications or undertaken repairs incorrectly or without our prior approval, or had third parties undertake such work.

The customer's entitlement to assert claims due to faults shall in all cases lapse six months following a complaint made within the required time period, however no sooner than the end of the compulsory warranty period. We are not responsible for correcting faults unless the customer has fulfilled its obligations due to us up to the point when the fault became apparent.

Changes in the design and shape of horticultural machinery and equipment

We reserve the right to make changes in design and shape, in particular with regard to deviations from the drawings and descriptions etc. during the delivery period, provided that the purchased object is not thereby significantly altered, rendered less effective or reduced in value and the customer can reasonably be expected to accept the modifications.

You have chosen to purchase a product of true quality.

We wish you every success with your product.

We would be most grateful if you would recommend our products to others.

Thank you

Your MAYER-TEAM

